

350W SM850

90-132VAC/180-264VAC

215*115*30mm

/ / /

-25 to +70

| | | | | |
|--|-----|--|-----------|------------|
| | | ± 1.0% | 5V ± 3.0% | 12V ± 1.5% |
| | | ± 0.5% | | |
| | | ± 0.5% | 5V ± 2.0% | 12V ± 1.0% |
| | () | 1500ns 50ns/230VAC 1500ns 50ns/115VAC | | |
| | () | 16ns/230VAC 12ns/115VAC | | |
| | | 90-132VAC/180-264VAC 240-370VDC(230VAC) | | |
| | | 47-63Hz | | |
| | () | 6.8A/115VAC 3.4A/230VAC | | |
| | () | 60A/230VAC | | |
| | () | 2mA/240VAC | | |
| | | 110% 140% load 3s | | |
| | | | | |

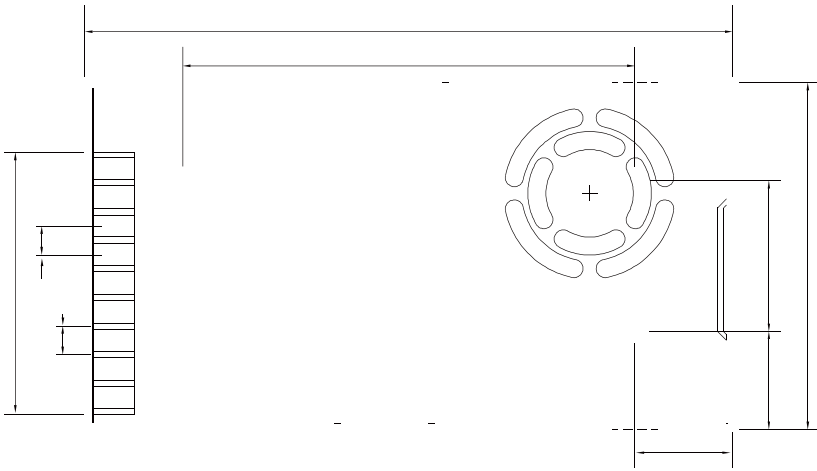

mm [inch] ± 0.5mm

